

ASSEMBLY INSTRUCTION

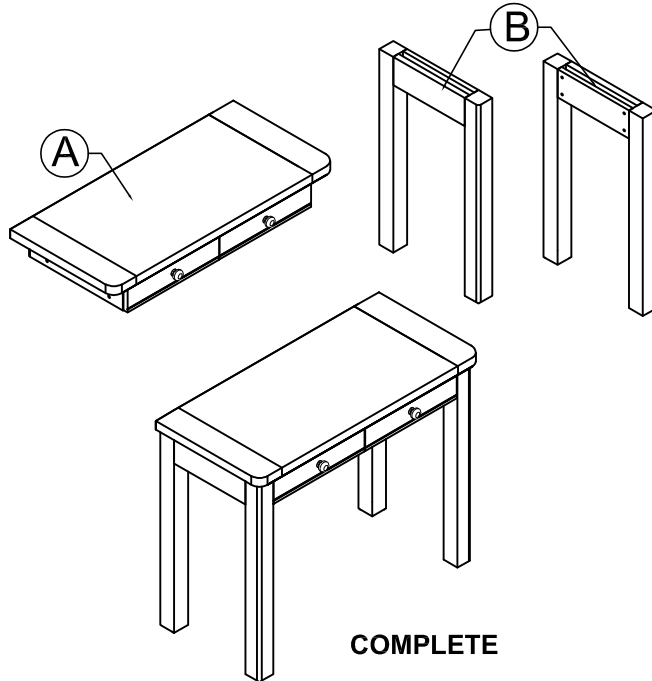







DRESSING TABLE / DESK

PART LIST

| No | Description | QTY | No | Description | QTY |
|----------|----------------|-----|----------|------------------|-----|
| A | CABINET | 1 | B | LEG FRAME | 2 |

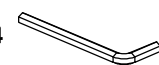
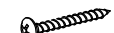

HARDWARE LIST

| No | Description | QTY | No | Description | QTY |
|----------|--|-----|----------|---|-----|
| 1 | Bolt M6x40 mm  | 8 | 5 | Bracket  | 2 |
| 2 | Flat Washer M6/M19  | 8 | 6 | Tie  | 1 |
| 3 | Spring Washer M6  | 8 | 7 | Screw M3x15  | 2 |
| 4 | Allen Key - 4  | 1 | 8 | Screw M4x35  | 2 |
| | | | 9 | Raw Plug  | 2 |

1

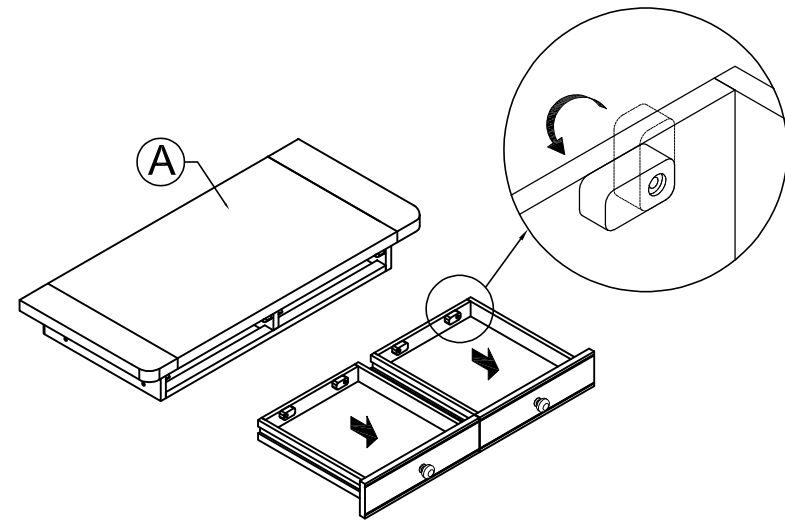

2

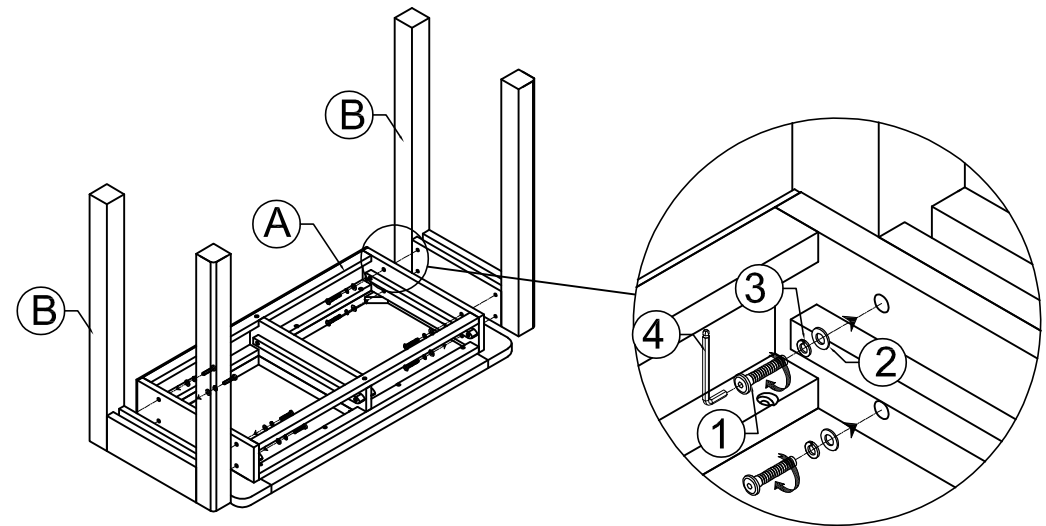

ASSEMBLY INSTRUCTION

DRESSING TABLE / DESK

3

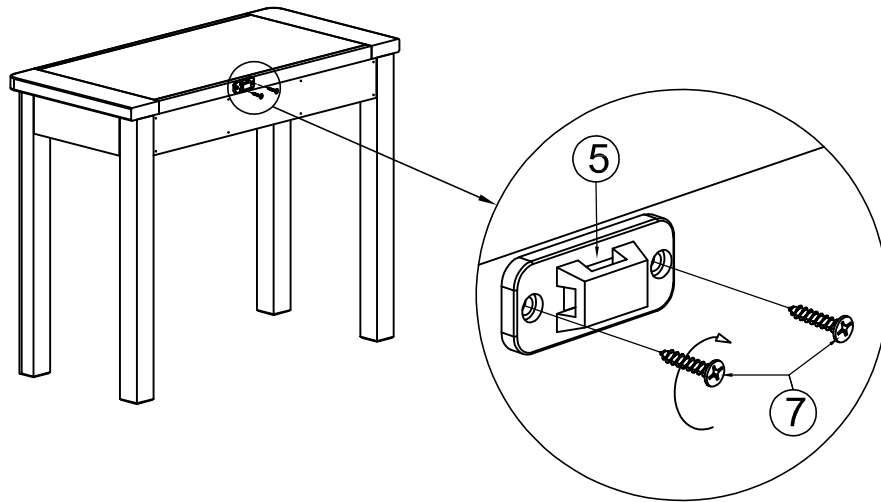

4

