













ASSEMBLY INSTRUCTION

DOUBLE ROBE WITH 2 SLIDING DOORS & 2 DRWS

No	LIST OF HARDWARE	FIG	Q.ty (pcs)
①	Bolt M6x35		8
②	Screw M4x35		16
③	Screw M4x30		10
④	Wooden Dowel Ø10x40		1
⑤	Flat Washer M6/M14		8
⑥	Allen key K4		1
⑦	Bracket		4
⑧	Tie		2
⑨	Screw M4x35		4
⑩	Raw Plug		4
⑪	Screw M3x15		16
⑫	Bracket L		4

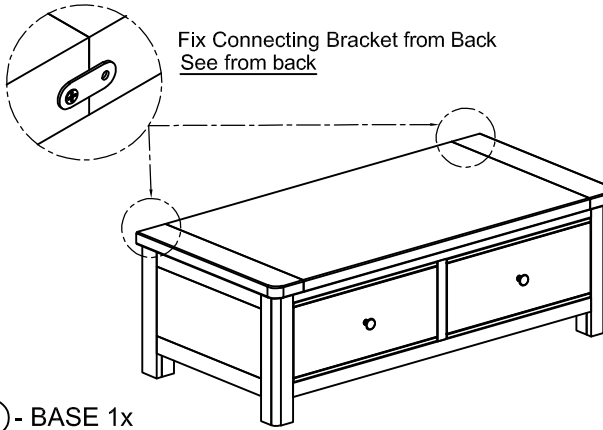

Ⓐ - BASE 1x

U - Shaped metal groove should be on top of front panel when assembling

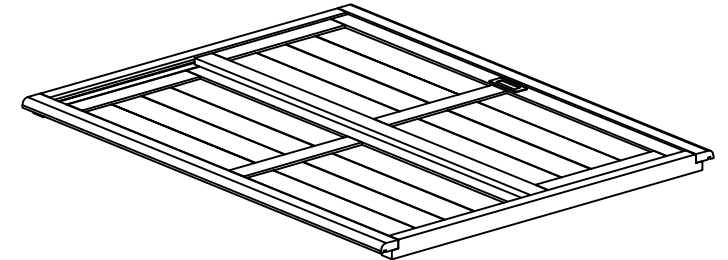

V - Shaped metal groove should on the bottom of the front panel when assembling to ensure the doors open & close correctly

Ⓑ - FRONT FRAME WITH DOOR 1X

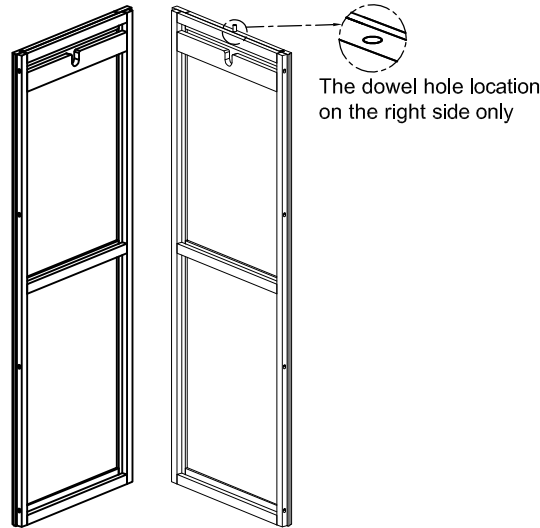

Ⓒ - RIGHT FRAME 1X AND LEFT FRAME 1X

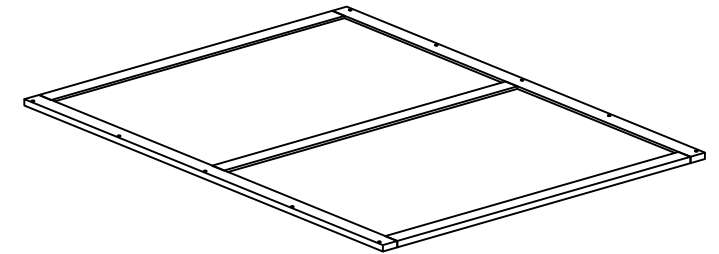

Ⓓ - BACK FRAME 1X

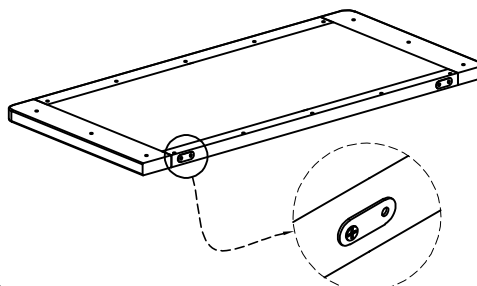
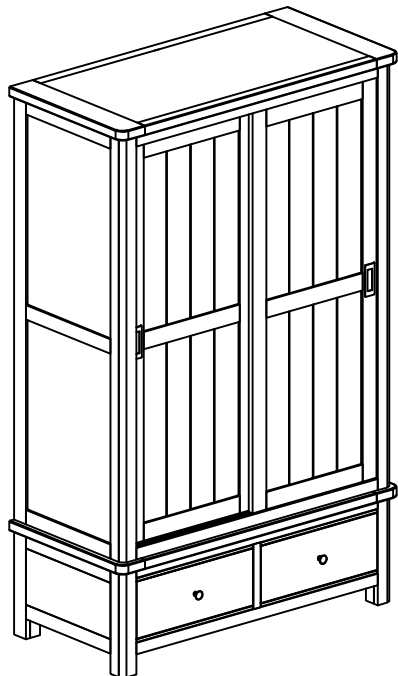

Ⓔ - TOP FRAME 1X



Ⓕ - HANGING RAIL 1X

STEP 1

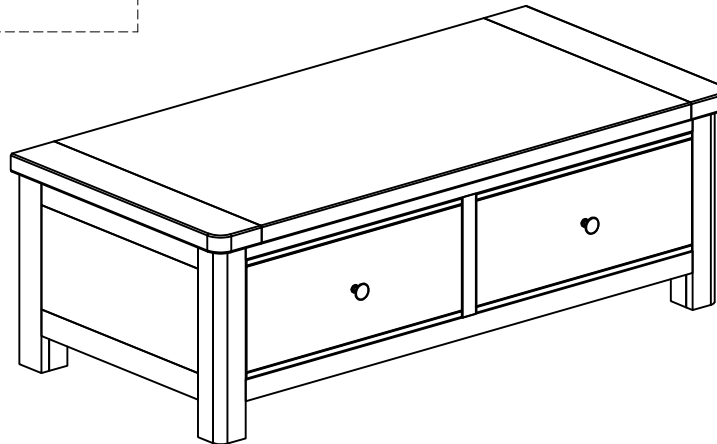
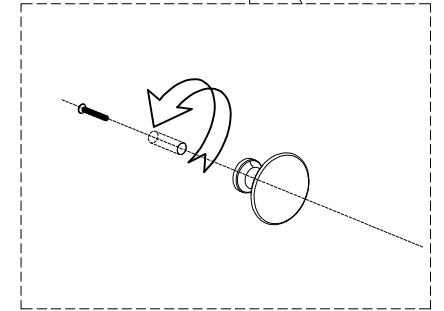
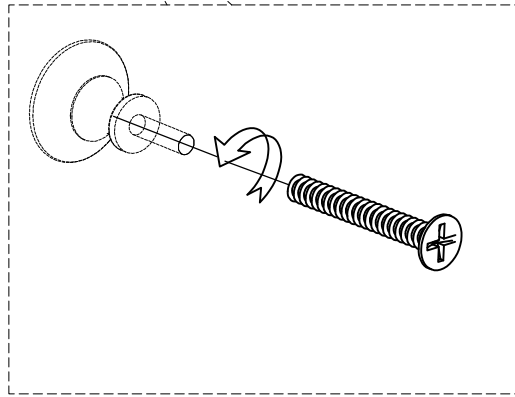
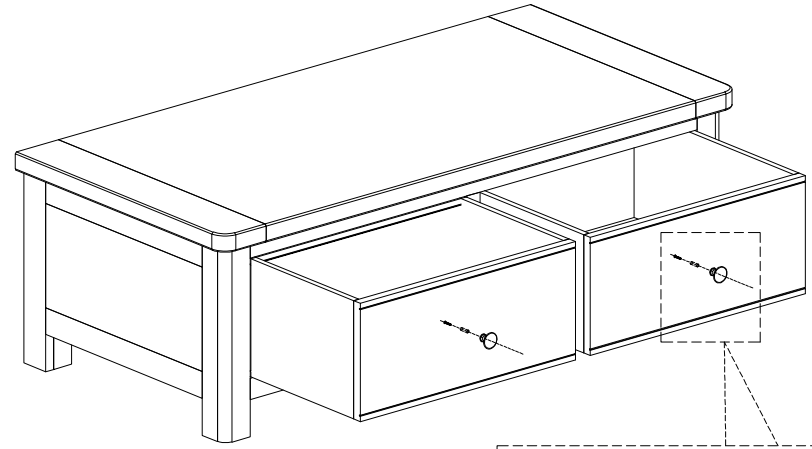
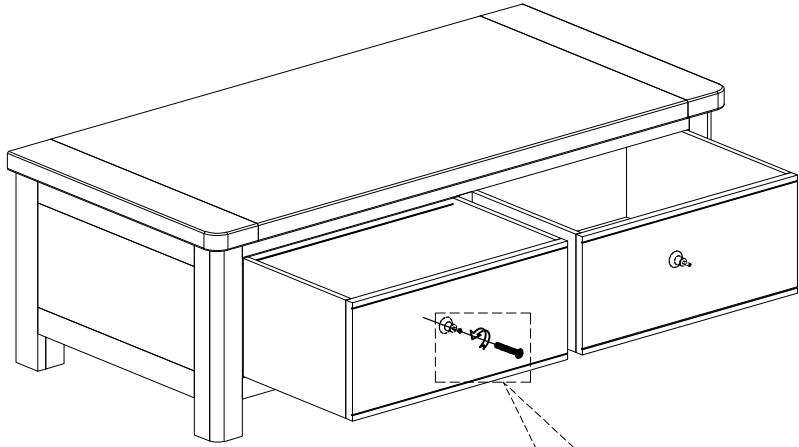

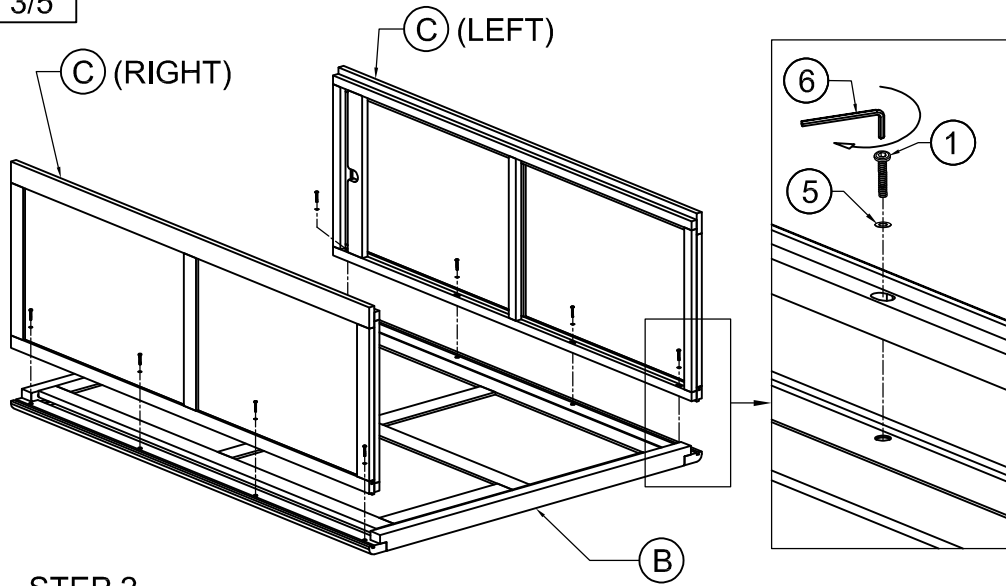

STEP 2

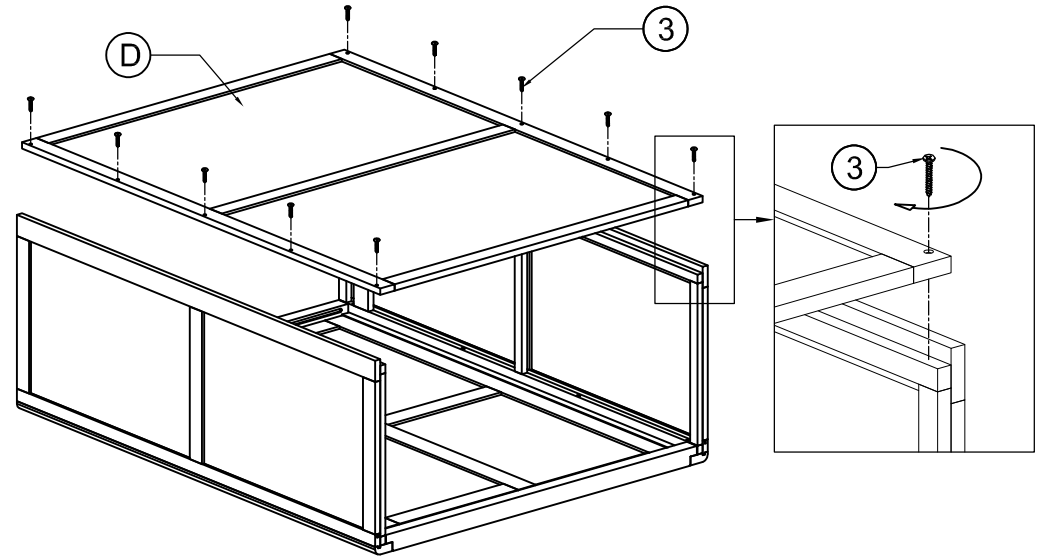

STEP 3

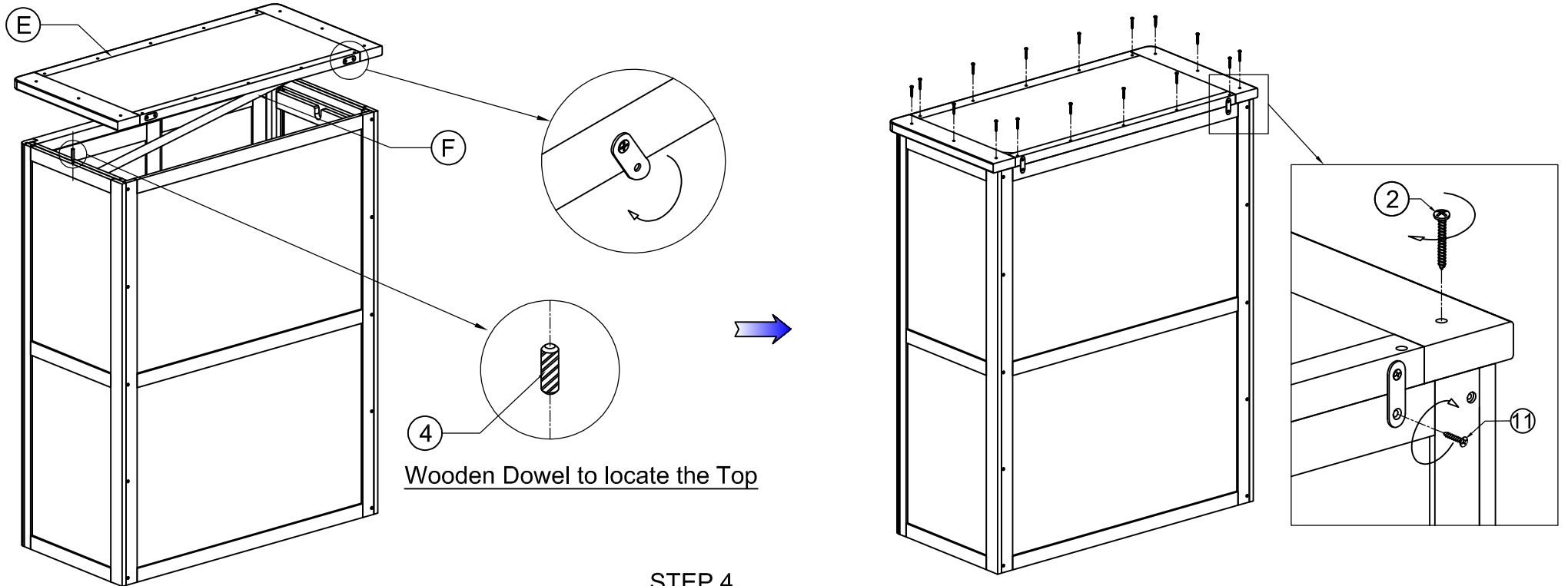

STEP 4

STEP 5

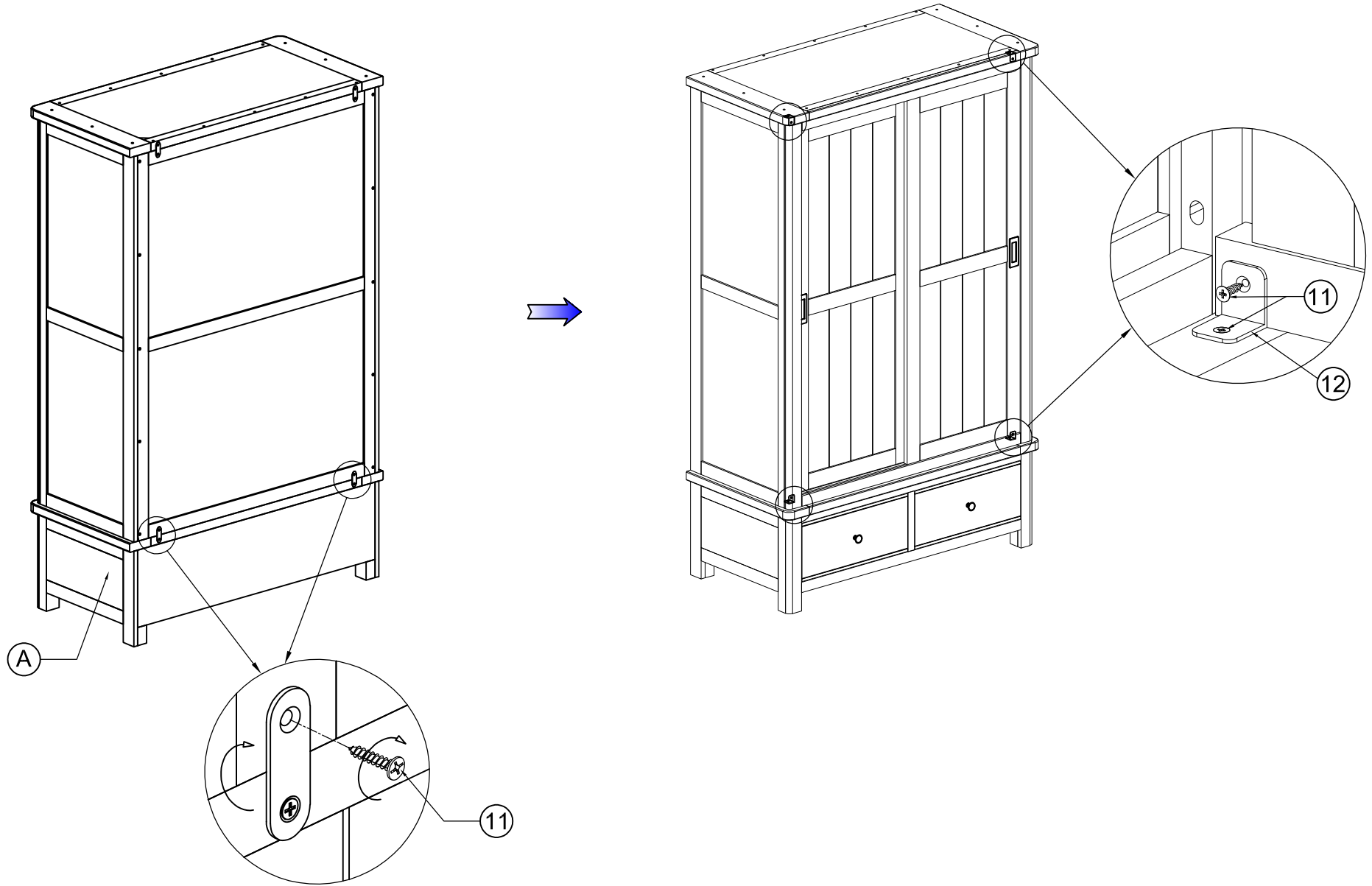

STEP 6

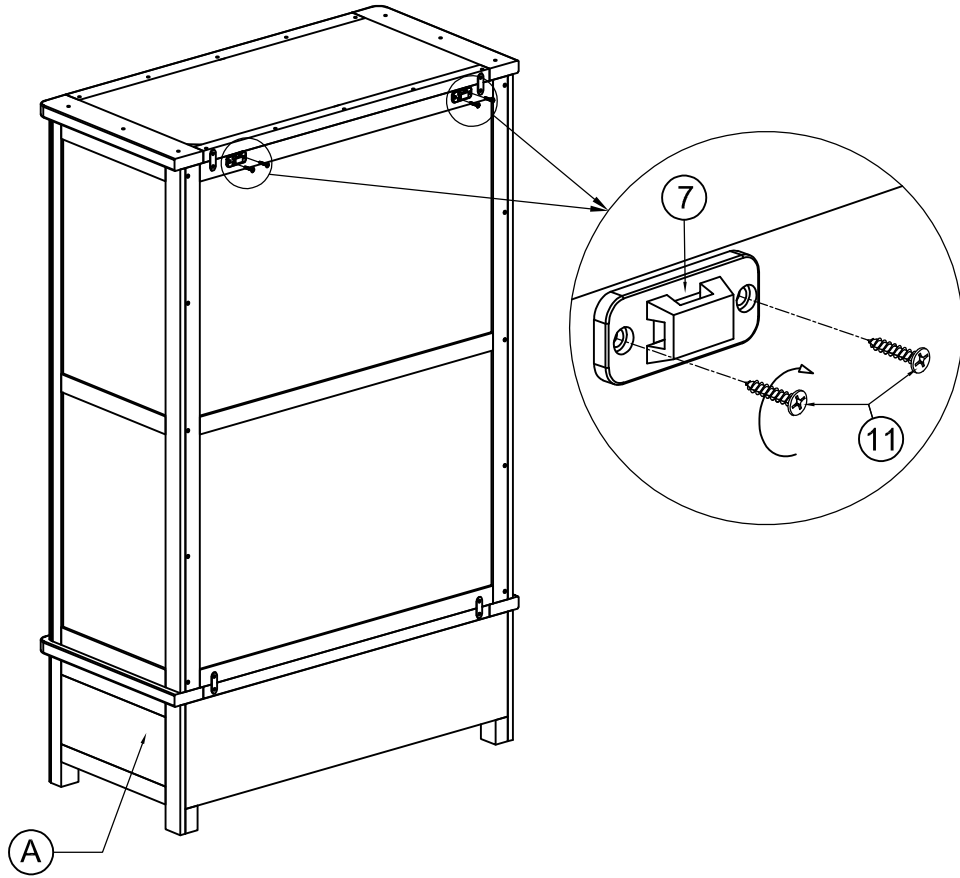

FINAL

