

ASSEMBLY INSTRUCTION

TWIN PEDESTAL DESK

PART LIST





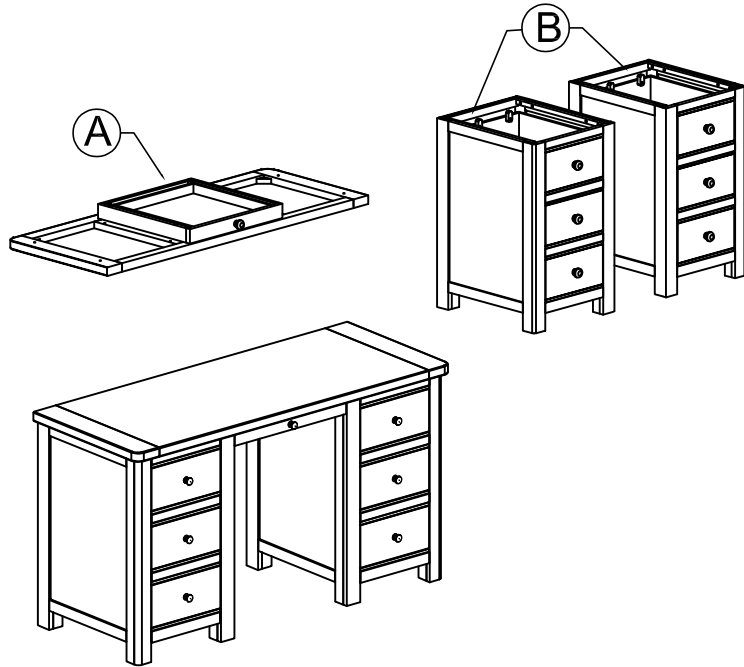



No	Description	QTY	No	Description	QTY
A	TOP	1	B	CABINETS	2

1

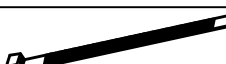

COMPLETE

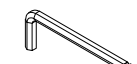
HARDWARE LIST

No	Description	QTY	No	Description	QTY
1	Bolts M6x30 mm 	8	5	Plastic bracket 	4
2	Spring Washers M6 	8	6	Tie 	2
3	Flat Washers M6/M12 	8	7	Screw Ø3x15 	4
			8	Screw Ø4x35 	4
4	Allen Key - 4 	1	9	Raw Plug 	4

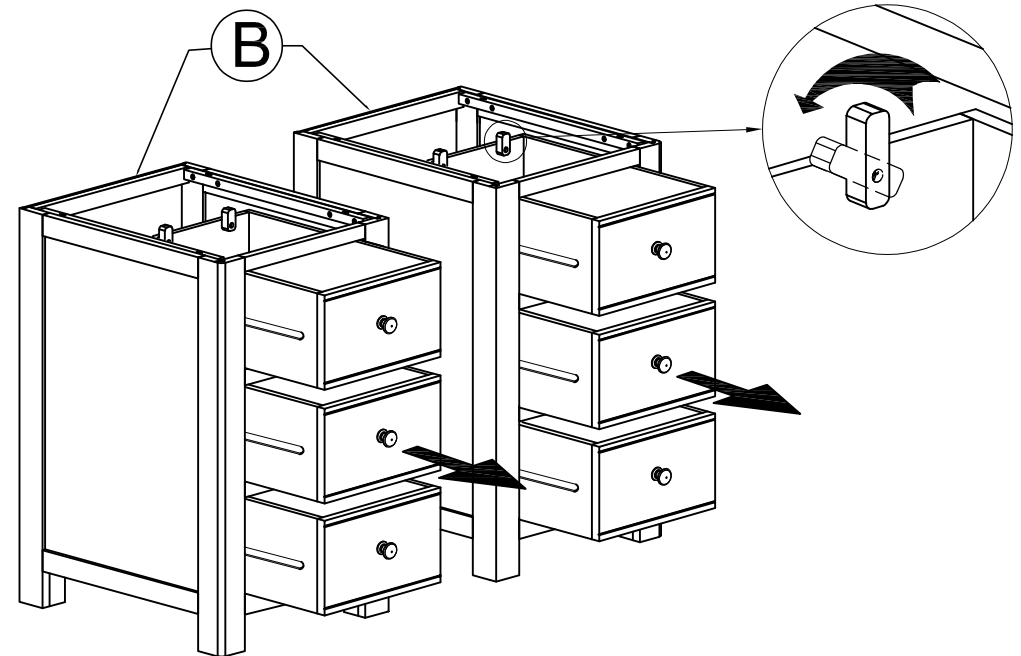

ASSEMBLY INSTRUCTION

TWIN PEDESTAL DESK

2

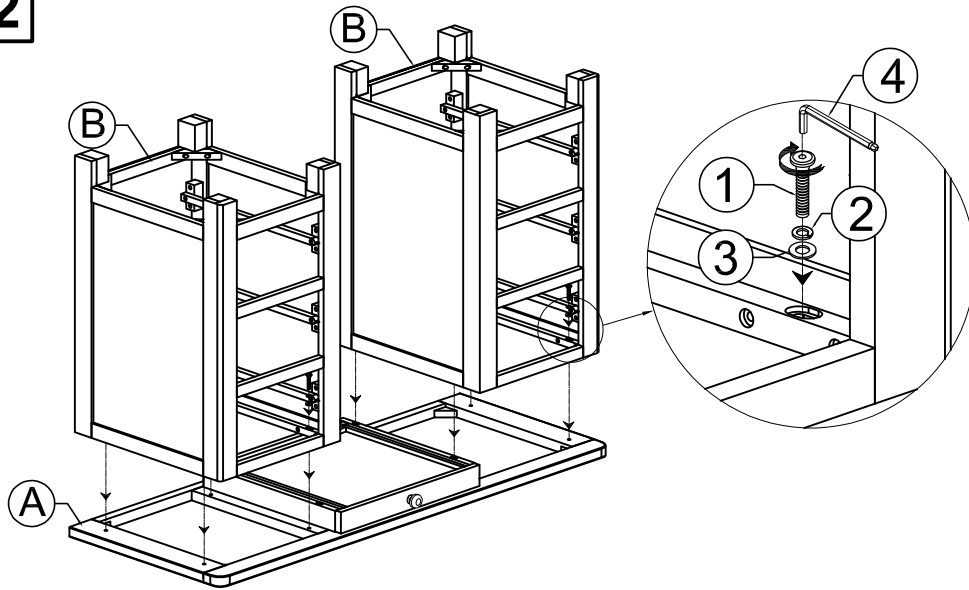

3

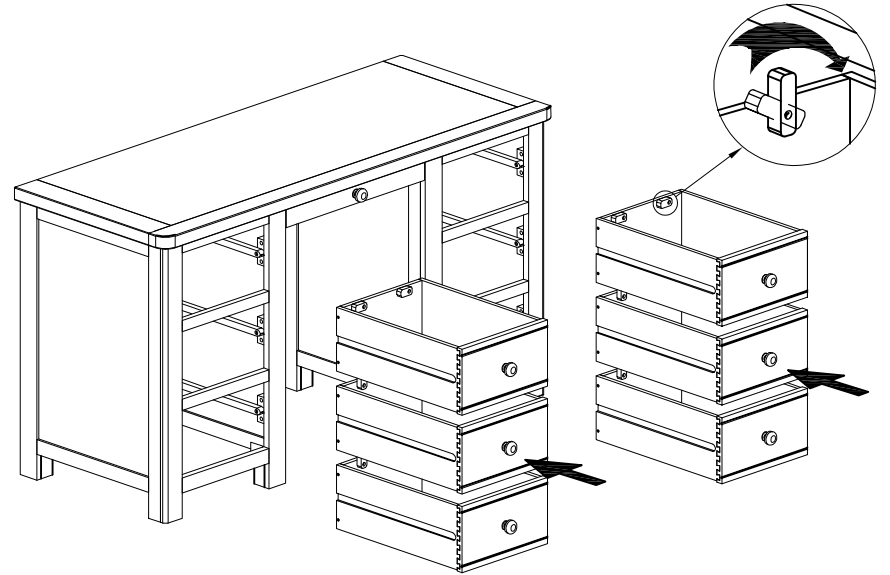

4

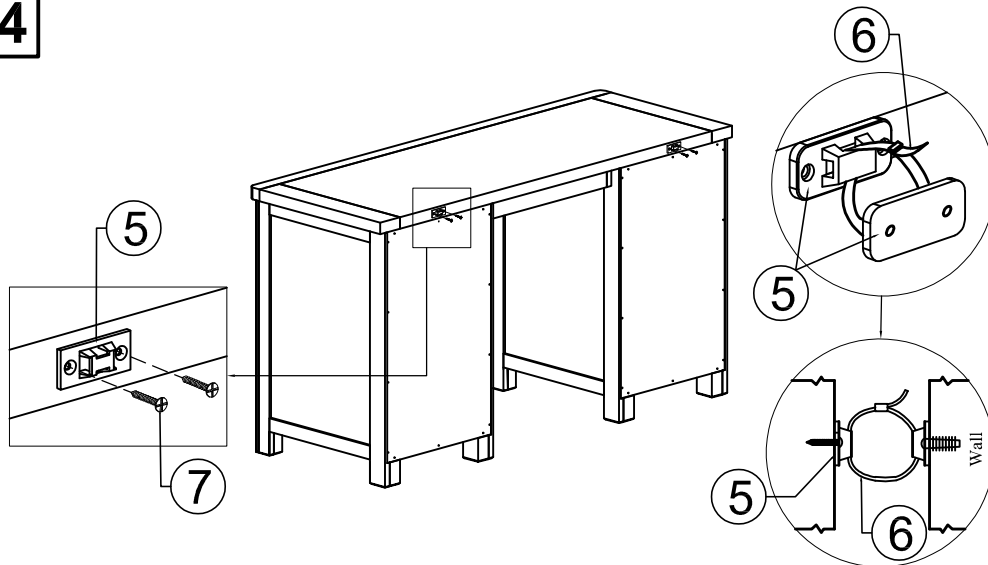

5

