

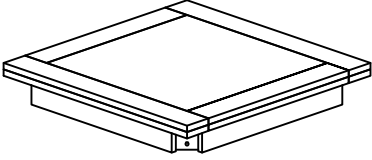

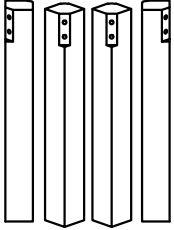

## ASSEMBLY INSTRUCTION SQUARE EXTENSION DINING TABLE

No.	Part name	Q'ty
A		1
B		4
No.	Hardware name	Q'ty
1	Bolt M10x60 	8
2	Spring Washer M10 	8
3	Flat Washer M10/M23 	8
4	Wrench 	1



STEP 1	STEP 2
STEP 3	FINAL

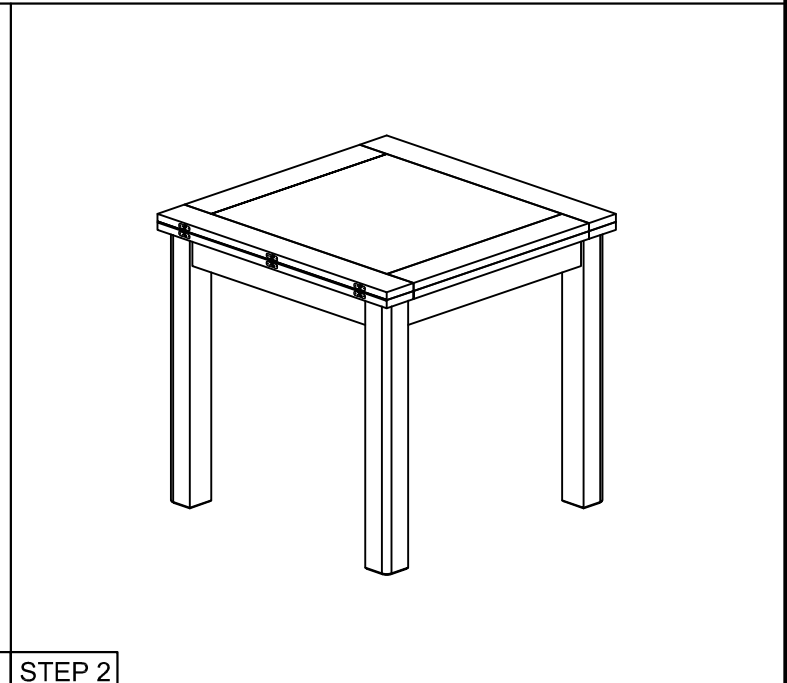
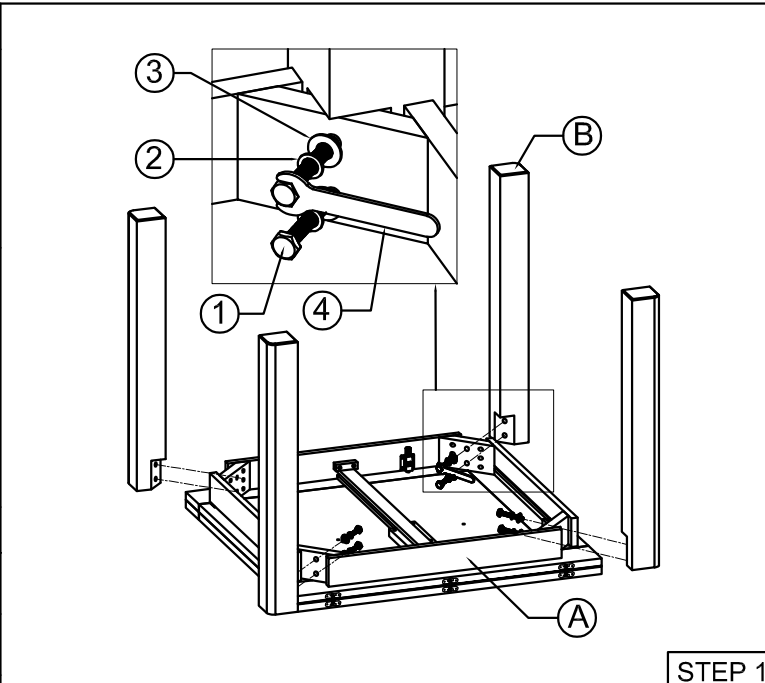